



Maximum Performance



DC 8, DC 16

FEATURES AND BENEFITS

- Very low energy consumption, only 0,5 kWh/kg, very short drying time, 42 minutes (DC 8)
- Four automatic programs and one program for time dry
- HTS - measures the level of humidity every single second, to determine exactly when the textiles are dry
- 16 m (DC 8), 32 m (DC 16) hanging length
- Double overheat-protection for increased security
- The top is removable for easier handling and installation
- Test program and error codes make it easier for maintenance
- Double sheet metal in sides and doors minimize loss of energy

- Hanging frame can be rotated 90° (DC 16), 180° (DC 8)
- Three fans (2 x DC 8) create perfect balance between evacuated and re-circulated air
- Service menu with possibilities to adjust the function of the cabinet
- CE approved

OPTIONS

- Single rack bar, instead of swinging rail
- Kit of 3 hook racks

DRYING CABINETS

TYPE		DC 8	DC 16
Loading capacity	kg/lb	Up to 8 / 17.6	16 / 35.2
Drying capacity	g/min	62*	81**
Hanging length	m	16	32
Drying time	min	42*	64**
Evacuated air	m ³ /h	340 (max)	550
Heating effect	kW	6	9
Total effect	kW	6.3	9.45
Energy consumption / kg	kWh	0.5	0.54
ELECTRICAL CONNECTIONS			
Electrical connection (standard)		3x380-415V +N 50/60Hz	3x380-415V +N 50/60Hz
Total effect	kW	6.3	9.45
Heating elements	kW	6	9
AIR CONNECTIONS			
Outlet exhaust	ø mm	125	160
Outlet airflow	m ³ /h	230	300
Pressure drop	Max Pa	70	260
SOUND LEVEL			
Airborne sound level	dB(A)	62	65
OPTIONAL ACCESSORIES			
Single bar	Part number	POD131070	POD131072
Hook rack, set of three	Part number	POD131071	POD131071
DIMENSIONS			
HxWxD	mm	1870x1200x640	1955x1800x800
SHIPPING DATA			
Net	kg	145	235
Gross (crate)	kg	159	275
Shipping volume	m ³	1.78	1.76

* Drying of 6 kg cotton (dry weight), washed and high-spun to 43% residual moisture, dried to 0% residual moisture.

** Drying of 12 kg cotton (dry weight), washed and high-spun to 43% residual moisture, dried to 0% residual moisture.

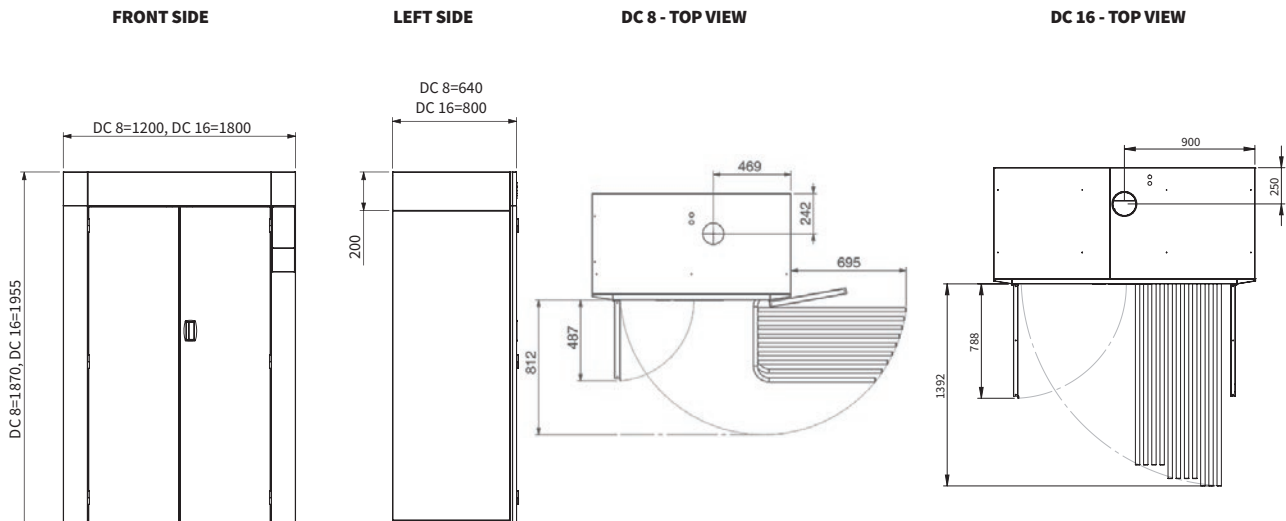

TO LEARN MORE, OR TO FIND A DISTRIBUTOR IN YOUR AREA, VISIT UNIMAC.COM
ALLIANCE LAUNDRY SYSTEMS - SHEPARD ST, RIPON WI 54971 - +1 800 587 5458

Consult your UniMac® distributor for details. For the most accurate information, the installation guide should be used for all design and construction purposes. Due to continuous product improvements, design and specifications subject to change without notice. The quality management systems at Alliance Laundry Systems® Ripon facility has been registered to ISO 9001:2008.

©2018 Alliance Laundry Systems LLC.

UniMac® by Alliance Laundry Systems