



Maximum Performance



UMB360, UMB500, UMB700

FEATURES AND BENEFITS

- Freestanding, high spin
- Oversized frame, bearings and drum
- Large drain valve 2x Ø 76 mm
- Easy access to all parts
- Frequency controlled motor
- Large door opening for easy loading and unloading
- Perforated lifting ribs: better washing results, lower water consumption
- Ecological washing programmes – significantly reduces water and electricity consumption
- Soap dispenser with 5 removable compartments
- Stainless steel cabinet
- RS485 & USB plug
- Designed with focus on ergonomics
- Patented inner door lock mechanism

OPTIONS

- Liquid soap pumps
- Weighing systems for optimization of water and soap consumption
- Isolation for energy and noise reduction
- Version without soap hopper
- Drain valve for water recycling
- Water sample tap
- Extra signalization of end of cycle
- Second display
- Lateral drain

CONTROL PROFORM TOUCH

- 7" full color touch screen display with swipe function: very intuitive for users
- user-friendly screen with operating instructions built in as part of the control
- Complete control content available in 34 languages
- 20 standard wash programmes, total memory capacity for 99 programmes
- Wireless communication enabling programming
- Automated service reminders remind users to maintenance tasks

HIGH SPIN HYGIENIC BARRIER WASHER EXTRACTORS

TYPE		UMB360	UMB500	UMB700
CAPACITY				
Drum capacity 1:10	kg/lb	36/79	50/110	70/154
Drum capacity 1:9	kg/lb	40/88	55,5/122	70/172
Drum volume	l	360	500	700
Drum diameter	Ø mm	775	775	775
Number of drums		1	1	2
Number of loading doors		1	1	2
Number of unloading doors		1	1	2
MOTOR				
Power	kW	4	7,5	7,5
DRUM SPEED				
Wash	rpm	41	41	41
Extraction	rpm	900	900	900
G-Factor		350	350	350
CABINET				
Door opening angle	°	155	155	155
HEATING				
100% hot water	°C	90	90	90
100% electrical	kW	36	48	60
Steam high pressure	bar	3-8	3-8	3-8
CONNECTION				
Electrical		3x200-240V 50/60Hz 3x380-415V 50/60Hz 3x440-480V 50/60Hz	3x200-240V 50/60Hz 3x380-415V 50/60Hz 3x440-480V 50/60Hz	3x200-240V 50/60Hz 3x380-415V 50/60Hz 3x440-480V 50/60Hz
Water inlet	inch	3x 1"	3x 1"	3x 1"
Steam inlet	inch	3/4"	3/4"	3/4"
Drain diameter	inch	2x 3"	2x 3"	2x 3"
DIMENSIONS				
HxWxD	mm	1700x1270x980	1700x1566x980	1700x2032x980
TRANSPORT DATA				
Gross	kg	1090	1280	1470
Net	kg	960	1130	1310
Packed HxWxD	mm	2005x1530x1255	2005x1830x1225	2005x2290x1255

*Tested in accordance of EN 604 56 norm. The data concerning dimensions of machines include all extended parts

FRONT UMB360 / UMB500

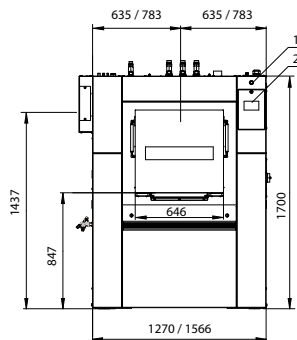

FRONT UMB700

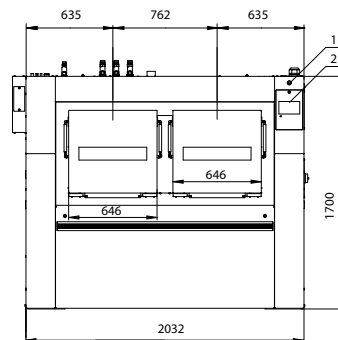

SIDE UMB360 / UMB500 / UMB700

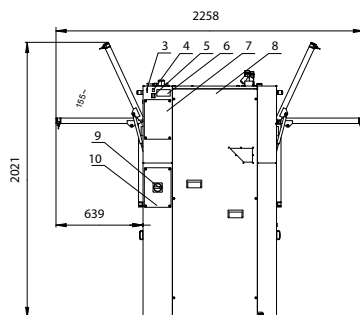

1. Emergency stop
2. Control panel
3. USB port
4. PC programming connection
5. Switch: steam / electric heating
6. Serial plate
7. Electrical signals liquid soap cover
8. Electrical components with frequency inverter cover
9. Main switch cover
10. Main switch